



TACT TA-4800

Two-Way Radio/Telephone Interconnect



ACMA Supplier Code: N468
ERAC Responsible Supplier Number: E1287

ISO9001 Certified

Document G/00123
Issue 14, 23/07/2014



Design Two Thousand Pty Ltd ABN: 45 005 014 639
9-11 Rose Street
Upper Ferntree Gully
Melbourne Victoria 3156 Australia
Telephone: +613 9758 5933 Facsimile: +613 9758 5560
Email: gen@design2000.com.au
Web Site: www.design2000.com.au

**All Rights Reserved,
Copyright © 2014, Design 2000 Pty Ltd**



BLANK PAGE

TACT TA-4800

TACT TA-4800 TWO WAY RADIO/TELEPHONE INTERCONNECT - 19" RACK MOUNT VERSION

Operator Manual - Document Number G/00123

CONTENTS

	PAGE
INTRODUCTION	
Features	1
Local and remote programming description	2
TACT Indicators and connectors	3
USING TACT	
Making a telephone call	4
Receiving a telephone call	4
Speed dialing	4
Last number redial	4
Out-dial line select (other than default) (Optional)	5
USER FEATURES	
Recorded voice announcement	5
Called indicator	6
Call counter	6
System PIN	6
Hold	6
Two line operation	7
FACTORY OPTIONS	
Alarm input	8
Alarm dialer	8
Auxiliary output relays	8
Paging	9
Paging speed dial	9
Hook flash	9
Local telephone	10
Call Barring	10
Automatic Diversion to an Individual Mobile or Talk Group (MOTOTRBO™ DTP Only)	10
SYSTEM CONFIGURATION	
System configuration codes	11
EPROM firmware version number	14
CONNECTION DIAGRAM	16
Connections	17
Audio level adjustments	20
Audio output to the radio (Tx)	20
Audio input from the radio (Rx)	20
Press to talk (PTT) output to radio	21
Carrier operated squelch (COS) input from radio	21
SUMMARIES	
Summary of user codes	22
Specifications	25
Speed dial index	26



DESIGN TWO THOUSAND PTY LTD

TACT TA-4800 RADIO/TELEPHONE INTERCONNECT

INTRODUCTION

TACT, the Telephone Access Control Terminal, interconnects a two-way radio system to a telephone line or PABX extension. It allows you to make and receive telephone calls on your two-way radio mobiles and hand-helds. Other features include paging, alarm and telemetry facilities.

Design Two Thousand Pty Ltd, established in 1968, has been making TACT units since 1987, and this TA-4800 is the new flagship model. It is the digital successor to the well-proven TA-7.

Things that make the new TA-4800 unique are full remote programmability without the need for a modem, real voice prompts to the user, and the many advantages of digital signal processing.

FEATURES

- Make and receive telephone calls easily
- 100 number speed dial
- Last number redial
- Manual patch facility
- Digital recorded voice announcement
- Digital personalised recorded voice announcement
- Called indicator
- Call counter
- Programmable PIN access
- Local and Full Remote programmability
- Two line capability
- DTMF dialing
- Dial tone detect
- Exchange (CO) or PABX line
- Programmable silence disconnect
- Programmable call time limit
- Busy tone detect
- Line reversal detect
- Loop current loss detect
- Data mode
- Programmable call barring
- Call progress display
- Hook flash (100 ms)
- Priority outdial line (L1 default)
- Call waiting on other line tone
- Manual / auto answer for each line
- Programmable ring delay for each line
- Programmable repeater tail timer (COS ignore after PTT release)
- Programmable VOX attack time (Signal detect count)
- Programmable VOX sensitivity (Activate level)
- Programmable VOX persistence (Hang timer)
- Programmable Digital VOX audio delay
- Programmable level adjustments
- Simplex / half duplex/ duplex
- Programmable tail defeat (radio VOX) sensitivity & persistence
- Repeater audio mode (strapable).
- Alarm input
- Alarm dialer
- Auxiliary output relays
- EPROM version number display
- RS232 port for status messages, programming and diagnostics
- RS232 ports for modem & telemetry Interface
- 12 Vdc nom. working (Ground insensitive)
- 1 RU, 19" rack mountable enclosure
- Two Year warranty
- ACMA Supplier's Code N468

OPTIONAL

- Paging:
 - DTMF selcall
 - Two tone page (Quickcall)
 - Five / six tone page (Selcall)
 - Programmable Two tone paging plan letter
 - Programmable pre-coded paging digits
 - Programmable Five /six tone paging plan
 - Programmable paging parameters
- 100 paging and selcall memories
- Emergency number dial mode
- Programmable CTCSS (PL) Encode

LOCAL AND REMOTE PROGRAMMING

All user programmed data, system options and tone detection parameters can be verified or changed from the inbuilt keypad:

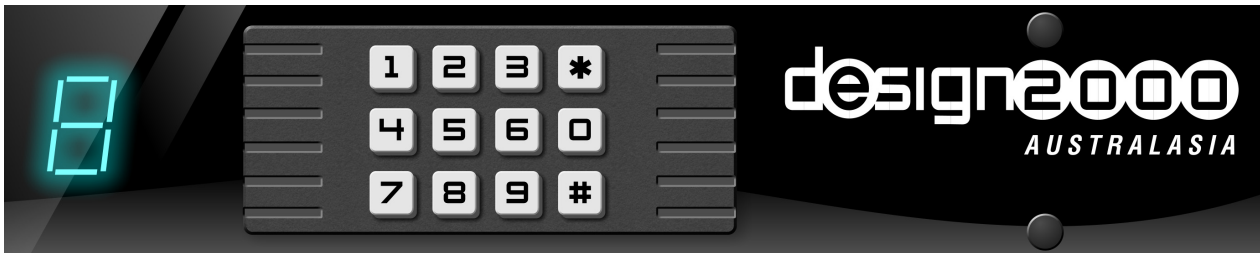

Programming is also possible from any telephone or radio on your system using DTMF tones. TACT's digitized voice synthesizer provides confirmation of programming changes and stored data.

Data retained in memory can also be interrogated and altered at higher speed using a PC.

User functions are easily selected by pressing the appropriate number keys. Access to reading or changing system options requires access codes as detailed later in this handbook.

PROGRAMMING PROCEDURES

There are three programming levels that can be accessed:

1. Making and receiving telephone calls
2. User features
3. System configuration

1. From The Keypad

Simply press the required number keys as detailed in this handbook. Confirmation is displayed to the user on the LED monitor.

2. From A Mobile Or Handheld Radio

The mobile radio must have a DTMF pad. Programming from the mobile is identical to that from the keypad. The only difference is that programming information is reported by digitized voice prompts and confirmation messages.

3. From The Local Telephone

Lift handset and programming is identical to that from a mobile.

4. From A Remote Telephone

Dial up TACT and wait for answer. You then dial a password and programming is identical to that from a mobile.

TACT INDICATORS

Programming progress and success is displayed on the seven segment LED monitor display. (Remote operation is prompted and confirmed by the voice synthesizer). The 7 segment monitor display also provides call progress information:

- 0 = silence
- 1 = busy tone
- 2 = modulated dial tone
- 3 = Number Unobtainable (N.U.) tone
- 4 = speech
- 5 = continuous tone
- 6 = indeterminate tone
- 7 = ringing tone
- 8 = unmodulated ringing tone
- 9 = random disconnect tone
- n.* = DTMF (monitor display shows DTMF digits from radio only!)

In addition to the monitor display, visual indication of operating progress is provided by six LEDs on the front panel marked 'POWER', 'READY', 'CONNECT', 'ON AIR', 'Tx', and 'Rx'.



The 'POWER' LED indicates that power is connected and that the internal fuse is intact. The 'READY' LED indicates that the system is ready for calls. The 'CONNECT' LED illuminates whenever the PSTN telephone line(s) is 'looped'. The 'ON AIR' LED illuminates whenever the audio path is open to the radio. The Tx and Rx LEDs indicate transmit (PTT) and receive (COS) from the radio.

TACT CONNECTORS

12Vdc power input:	BL-2 plug
Telephone line:	RJ12
Second telephone line:	RJ12
Radio:	RJ45
RS232 Port	RJ45 (Call Data /Diagnostics)

Please refer to 'CONNECTIONS' for connector pin-out details.

MAKING AND RECEIVING TELEPHONE CALLS

Making a Telephone Call

1. Dial the required telephone number.
(If you make a mistake, press * and start dialing again).
2. Press #.
3. Listen for "*TACT dialing*".
4. Wait for answer, then proceed with conversation.
5. To end the call, press ##. Listen for "*Line disconnected*".

Receiving a Telephone Call

Manual Answer Mode

1. When a call comes in, you will hear a ringing sound over the radio "*ring...ring...*".
2. Press * (in between the rings) to answer the call.
3. Listen for the "*bee-boo*" 'Connect' tone.
4. Proceed with conversation.
5. To end the call, press ##. Listen for "*Line disconnected*".

Note: The ringing sound is distinctly different if a call comes in on line two.

Auto Answer Mode

1. When a call comes in, you will hear the "*bee-boo*" 'Connect' tone or "*Line connected*".
2. Proceed with conversation.
3. To end the call, press ##. Listen for "*Line disconnected*".

SPEED DIALING

Abbreviated dialing of up to 100 of your most frequently called telephone numbers.

To Store Speed Dial Numbers

1. Press *2.
2. Press xx, where xx is the required memory location (00-99).
3. Enter the required number.
 - Note that you may enter dialing pauses, * and # as part of the number. *# = dialing pause, ** = * and ## = #
4. Press #.
5. Listen for "*The number is nnnnnnnn*".
6. NOTE THE NUMBER DOWN IN THE SPEED DIAL INDEX (second last page).
7. To check the number in memory, press *2 xx #.

To Dial Speed Dial Numbers

1. Press #.
2. Enter required memory location (00-99).
3. Listen for "*TACT dialing*".
4. Wait for answer, then proceed with conversation.
5. To end the call, press ##. Listen for "*Line disconnected*".

LAST NUMBER REDIAL

1. Press # #.
2. Listen for "*TACT dialing*".
3. Wait for answer, then proceed with conversation.
4. To end the call, press ##. Listen for "*Line disconnected*".

OUT-DIAL LINE SELECT (OTHER THAN THE DEFAULT) AND THEN MAKE A CALL (OPTIONAL)

This allows you to make calls from Line 2 of TACT.

1. Press # n #, where n is 2 or 1 (line 2 or line 1).
2. Dial the required telephone number.
3. Press #.
4. Listen for "TACT dialing".
5. Wait for answer, then proceed with conversation.
6. To end the call, press ##. Listen for "Line disconnected".

Note: You can dial speed dial numbers by dialing # 00-99 instead of steps 2 & 3.

USER FEATURES

RECORDED VOICE ANNOUNCEMENT (OPTIONAL)

TACT can play a digitally Recorded Voice Announcement (RVA) to the telephone caller before the call is directed to the field. The 'RVA' can be a standard announcement or a personally recorded announcement, eg. "You are being connected to a two-way radio". Please note that the personal announcement (PRVA) only works when TACT is programmed for auto answer mode.

Recording Your Personalised Recorded Voice Announcement (PRVA)

The system allows you to record your own announcement of up to 60 seconds.

From a telephone, dial TACT, wait for answer and access remote programming mode with *67PIN#, then:

1. Press * 78 # and listen for the "Beep".
Immediately commence dictating your announcement clearly into the telephone. If you exceed 60 seconds, TACT will replay what has been recorded. If you want to re-record your announcement, repeat step 1.
2. When recording is complete immediately press #. Your announcement will be replayed to you.
3. To review your announcement you can press * 79 #.
4. If you want to disable the personalised RVA, press * 78 # # in quick succession. Your previous recording is also erased.

RVA Summary

- * 78 # = record personalised announcement
- # = stop recording
- * 79 # = review personalised announcement
- * 78 ## = Disable and erase PRVA
- # * # = Exit programming

CALLED INDICATOR

If you leave your vehicle and incoming calls are not answered, TACT will register unanswered calls. You can check this from the radio only.

To Read the Unanswered Call Indicator

1. Press * 30 # and listen for either "*No calls*" or "*n calls*", where n was the number of unanswered calls. The unanswered calls register is then automatically reset.

CALL COUNTER

TACT automatically counts the number of calls connected to the field. You can read the call counter from the radio only.

To Read the Call Counter

1. Press * 31 #. TACT responds "*Call count nnnn*".

To Reset the Call Counter

1. Press * 31 0 #. TACT responds "*Call count 0000*".

SYSTEM PERSONAL IDENTIFICATION NUMBER (SYSTEM PIN)

TACT can be programmed to operate only after a valid PIN has been entered. All users on the system are required to insert the PIN before dialing or programming. It can prevent unauthorised use, and allow multiple TACT units to be used on the same radio frequency.

To Program the System PIN

1. Press * # p...#, where p... is the required PIN (1 – 8 digits).
 - This number cannot be recalled, it can only be over-written.

HOLD

Placing a Call on Hold

1. Press *1.

To Take the Call off Hold

1. Press *1.

TWO LINE OPERATION

To End a Call in Progress and Answer an Incoming Call on the Other Line

1. Press ##.
2. Press *1.

To Hold First Call and Answer an Incoming Call on the Other Line

1. Press *1.
2. Press *.

Alternate between Calls on Hold

1. Press *2.

Conference Call *(Not Yet Implemented)*

1. Press *3.

To Hang up on the Last Person Spoken to and Return to the Other

1. Press ##.
2. Press *1.

FACTORY OPTIONS

ALARM INPUT

Alarm systems such as a security alarm, a door open alarm or mains failure alarm can be connected to the TACT alarm input (Pins 4 & 5 of the 'ALARM' connector). Should the alarm be triggered, TACT can:

- i. Send an "*Alarm activated*" message to air (see '*System Configuration*').
- ii. Dial up to four telephone numbers and send an "*Alarm activated*" message to line (see below).
- iii. Initiate a Page call.
- iv. Activate auxiliary output relay one to perform an external function.

ALARM DIALER

TACT can perform the function of an alarm dialer. Up to 4 different telephone numbers can be dialed in succession where the "*Alarm activated*" message is played to each number for thirty seconds. When you receive an alarm call, you can press # to acknowledge the alarm and stop TACT from dialing any further for that alarm.

To Enter the First Alarm Dial Number

1. Press * 81 x nnnnnnnnn #, where x is the number of dial attempts and nnnnnnnnn is the number to be dialed.

To Enter the Second Alarm Dial Number

1. Press * 82 x nnnnnnnnn #, where x is the number of dial attempts and nnnnnnnnn is the number to be dialed.

To Enter the Third Alarm Dial Number

1. Press * 83 x nnnnnnnnn #, where x is the number of dial attempts and nnnnnnnnn is the number to be dialed.

To Enter the Fourth Alarm Dial Number

1. Press * 84 x nnnnnnnnn #, where x is the number of dial attempts and nnnnnnnnn is the number to be dialed.

To Erase a Number

1. Enter a single '0' in place of x nnnnnnnnn as detailed just above.

AUXILIARY OUTPUT RELAYS

The Auxiliary Output Relays can be connected to most switchable systems. This provides for the control of sirens, security systems, power gates, electric door strikes and more. The relay(s) can remain latched, automatically reset, **or automatically be activated by certain events**. See page 18 for connection details.

To Operate the Relay One

1. Press * 07 1 #. Listen for "*Relay one operated*".

To Interrogate the Relay One State

1. Press * 07 #. Listen for "*Relay one operated*" or "*Relay one idle*".

To Reset the Relay One

1. Press * 07 0 #. Listen for "*Relay one idle*".

To Operate the Relay Two

1. Press * 08 1 #. Listen for "*Relay two operated*".

To Interrogate the Relay Two State

1. Press * 08 #. Listen for "*Relay two operated*" or "*Relay two idle*".

To Reset the Relay Two

1. Press * 08 0 #. Listen for "*Relay two idle*".

PAGING

Pagers, mobiles and handhels with paging decoders can be selectively called from any DTMF telephone or from a mobile with a DTMF pad. TACT can encode most two tone (quickcall) and five tone (selcall) paging protocols. Paging plans and parameters are field programmable but best specified at the time of ordering.

TO INITIATE A PAGE CALL

Two Tone Page Call (Quickcall)

1. Press * 72 nn #, where nn is the two tone number.

Five Tone Page or Selective Call (Selcall)

1. Press * 75 nnnnn #, where nnnnn is the five tone number.

PAGING SPEED DIAL (Optional)

A combination of up to 99 two tone and/or five tone numbers can be stored in memory. This enables abbreviated speed dialing of two tone paging (quickcalls) and five tone paging (selcalls).

To Store Two Tone Page Numbers in Memory

1. Press * 42 nnn # xx, where nnn is the two tone page number and xx (01-99) is the memory location.

To Store Five Tone Page Numbers in Memory

1. Press * 45 nnnnn # xx, where nnnnn is the five tone page number and xx (01-99) is the memory location.

To Speed Dial a Two Tone or Five Tone Paging Call from Memory

1. Press * 4 xx #, where xx is the memory location. Listen for paging tones.

HOOK FLASH

A Hook flash (also called 'Recall' or timed loop break) is used to facilitate PABX and electronic exchange functions such as transfer, hold and recall.

For TACT To Generate a Hook Flash (Timed Loop Break)

1. Press * 6.

LOCAL TELEPHONE (OPTIONAL)

The local telephone is a 'master terminal' that can be used as a monitor, a paging terminal, a central point of contact for field units, a terminal to place calls for mobiles and a terminal to intercept and screen incoming calls to be patched through to the field. In addition, field units can contact the office staff by ringing the local telephone. Telephone calls on the local telephone can either be private or broadcasted.

Calling the Local Telephone from a Mobile

1. Press * 90 #.

Calling a Mobile from the Local Telephone

1. Lift handset and voice call or page mobile.

To Turn On Local Telephone Privacy Mode

1. Press * 91 1 #.

To Turn Off Local Telephone Privacy Mode

1. Press * 91 0 #.

All other programming from the local telephone is identical to that from a mobile or remote telephone.

CALL BARRING (*Not Yet Implemented*)

The only easy way of restricting mobile users from dialing outside local or long distance numbers is to limit the number of digits that they are allowed to dial. Please note that emergency numbers are always allowed (000, 111, 911, 112, 999, etc.). For more comprehensive call barring, use the barring facilities of your PABX or your telephone company.

To Set the Number of Digits that can be dialed from a Mobile

From the Keypad of TACT only:

1. Press * 59 nn #, where nn can be 00-24.
2. To check the number of digits allowed, press * 59 #.

AUTOMATIC DIVERSION TO AN INDIVIDUAL MOBILE OR TALK GROUP (MOTOTRBO™ DTP ONLY):

This mode is used to automatically divert incoming telephone calls to an individual radio or radio talkgroup on a MOTOTRBO™ radio system. When an incoming telephone call is received, TACT dials the mobile number stored in memory as programmed below. Callers into TACT will hear normal ringback tone until the call is set up to a mobile.

To Activate Automatic Diversion to a Mobile or Talk Group from the Keypad of TACT:

- ① Press * 86 tsr...r#, where tsr...r is the Target ID to which incoming telephone calls will be diverted. The Target ID consists of Call Type (7 or 8), Time Slot (1 or 2) and the Radio ID (CPS configurable).
 - For Single Site and IPSC: Target ID = Call Type + Slot # + Radio ID.
 - For Capacity Plus: Target ID = Call Type + Radio ID.
 - Target ID length is CPS configurable.
 - Call Type = 7 (individual) or 8 (talkgroup).
 - Slot # = 1 or 2.
- ① To turn this option off and revert to Auto-Answer / Manual Dial mode press * 86 0 #.

Telephone calls coming into **Line 2** of TACT can be diverted to a different individual radio or radio talkgroup. Instructions are the same as above but use *87 tsr...r#.

If a call is up on Line 1 and a call comes in on Line 2, Line 2 will ring until the call on Line 1 has finished. Likewise if a call is up on Line 2 and a call comes in on Line 1, Line 1 will ring until the call on Line 2 has finished.

SYSTEM CONFIGURATION

Programming can be done from the TACT inbuilt keypad, remote telephone or radio.

The programming is the same from the keypad, remote phone or the serial port. **An extra two steps are required when accessing programming from a phone or radio. After connection, type *67PIN# (where the default PIN = 1234) to enter programming mode. To exit remote programming mode press ##.**

1. Press *6703# to enter system configuration programming mode.
2. Press *nn, where nn is the required option number from the table below.
 - TACT then reports the selected option number and its current status.
3. Enter a new value as required.
 - TACT then reports the option number and its new status.
4. Press *# to save and exit, OR
Press # to scroll to the next option OR
Press *nn, where nn is another required option number from the table below.
5. Enter a new value as required.
 - TACT then reports the selected option number and its new status.
6. Press *# to save and exit (or press ** to abort all changes)

Command Summary

*6703#

* nn where nn is option number

n... = entry

= scroll

** = abandon

* # = store & end

OPTION CODES

Code	Function	Range	Default	Description
*01	Reversal On Idle Ignore Incoming telephone Calls	0,1	0	0 = enable CPC detection (detect reversal) 1 = disable CPC detection (ignore reversal)
*02	Reversal On Idle Ignore Outgoing Calls	0,1	1	0 = enable CPC detection (detect reversal) 1 = disable CPC detection (ignore reversal)
*03	Reversal On Answer Ignore	0,1	0	0 = enable ROA detection 1 = disable ROA detection NOT USED.
*04	Decadic Dialing	0,1	0	0 = DTMF 1 = Decadic NOT USED
*05	Dial tone Ignore	0,1, 2-9	1	0 = dial out as soon as dial tone is detected. If no dial tone within 4 seconds, hang up. 1 = dial out as soon as dial tone is detected. If no dial tone within 2 seconds, dial regardless. n = Ignore dial tone and dial after n seconds, where n = 2 – 9.
*06	Delay After First Digit for 'outside' access	0,1	0	0 = no delay 1 = 2 second delay after first digit when dialing.
*07	Loop Break on silence	0,1	0	0 = no loop break 1 = momentarily hang up phone line when silence detected for 20 seconds on an incoming call. NOT IMPLEMENTED
*08	Digit Limit	03-21	21	21 = maximum digit limit other = max number of digits that can be dialed by TACT
*09	Hook flash Time	0-3000	0100	ms for hook flash

*10	Manual/Auto Answer - Line 1 (See *36 for Line 2)	0-3	3	0 = Auto Answer 1 = Manual Answer 2 = Delayed auto answer 3 = PTT to answer
*11	Answer Delay	0-255	000	Seconds before auto answering a call or sending ring tone to radio. Also used to set delayed auto answer time
*12	Ring Voltage Off Time	0-9	5	Seconds maximum gap between ringing voltage bursts.
*13	Absolute signal level detect (Line VOX minimum activate level)	0-255	080	qdB. Minimum detect threshold for telephone lines. Bigger is less sensitive
*14	CTCSS encode	00-50	00	The CTCSS tone to use for this line. NOT IMPLEMENTED
*15	Silence Disconnect from telephone line	0-255	002	Minutes of silence to disconnect phone line. Could be used for no Tx timeout
*16	Total call time limit	01-99	60	Minutes total call time limit
*17	Continuous tone disconnect	000-255	010	Seconds of continuous tone before disconnection. 000 = continuous tone allow & for fax data
*18	Malicious call trace	1,2	1	1 = normal 2 = hook flash on incoming call. NOT IMPLEMENTED.
*19	PIN required on phone line to access radio	0,1	0	0 = normal 1 = PIN required to access radio Must not be in manual answer mode.
*20	Who Called Enabled	0,1	0	0 = normal operation 1 = invite to leave who called info NOT IMPLEMENTED
*21	Two Tone (Quickcall) Plan	00-20	16 (S)	Motorola two tone paging plan. 0=A, 1=B etc no I or Q
*22	Two tone precoded digits	up to 3	None	precoded digits preceding a two tone page
*23	Five Tone (Selcall) Plan	0-3	1	0 = EIA 1 = CCIR 2 = EEA 3 = ZVEI
*24	Five Tone tone period	0-3000	0040	ms tone period when paging
*25	Lead in period	0-3000	0500	ms from PTT to page send.
*26	Silence gap	0-3000	0045	ms gap between preamble tone and five tone page
*27	Preamble Tone	0-11	12	five tone preamble, 12 = Off
*28	Preamble Tone Length	0-3000	0000	five tone preamble duration
*29	Five Tone precoded digits	up to 5	None	digit prefixed to a five tone page. Press # after entering less than 5 digits
*30	Preferred line	0,1	0	Preferred out-dialing line. 0=line 1 1=line 2
*31	Call waiting tone	0,1	0	0 = no call waiting tone 1 = call waiting tone AUTOMATIC
*32	Radio Busy Indicator	0,1	0	0 = no answer when radio busy 1 = message when radio busy NOT IMPLEMENTED
*34	Voice Prompts	0-3	3	0 = voice prompts & beeps to radio and phone 1 = beeps to radio and phone 2 = just beeps to radio but no beeps to phone line 3 = just soft tones from Speech EPROM. Two short tones for connect and longer tone for disconnect to both radio and phone. No loud beeps to either party.

*36	Manual/Auto Answer – Line 2 (See *10 for Line 1)	0-3	3	0 = Auto Answer 1 = Manual Answer 2 = Delayed auto answer 3 = PTT to answer
*40	Radio Mode	1-4	1	(0=OFF) 1 = Simplex 2 = Tail Defeat 3 = Half Duplex 4 = Full Duplex 5 = MAP27 6 = Serial Control, Simplex 7 = HF VOX mode (not fully tested)
*41	Digital Mobile Radio Protocol	0-2		0 = Conventional PMR 1 = MOTOTRBO™ DTP 2 = Kenwood NXDN
*42	Digital VOX Audio Delay	0-1000	0500	ms of audio delay after keying transmitter. (Prevent syllable loss from telephone party)
*43	COS Ignore after PTT off (Repeater tail ignore) in VOX slam-back mode only	0-3000	0420	ms ignore COS after PTT released. (ms from PTT off until COS recognized to prevent oscillation between Tx and Rx)
*44	Interconnect Facility Disable	0,1	0	0 = TACT Interconnect facility enabled 1 = TACT Interconnect facility disabled NOT IMPLEMENTED
*45	Redial Busy	0,1	0	0 = terminate on busy number 1 = redial busy number NOT IMPLEMENTED
*46	Alarm Dialer	0-2	1	0 = no alarm dialer 1 = alarm dial on alarm input – latched start (Number(s) must be programmed – refer to 'Alarm Input') 2 = alarm dial on alarm input – pulsed start
*47	Remote On Off	0,1	0	1 = normal 2 = allow remote control on/off NOT IMPLEMENTED
*48	Unanswered call indicator	0,1	0	0 = normal 1 = allow caller to leave number NOT IMPLEMENTED
*49	Aux 1 output relay mode	0-5	1	0 = OFF 1 = on for 2 seconds (NOT while button pressed) 2 = latch on or off 3 = on for 2 minutes 4 = follow alarm input 5 = on while telephone line 1 is looped
*50	Aux 2 output relay mode	0-5	1	0 = OFF 1 = on for 2 seconds (NOT while button pressed) 2 = toggle on or off 3 = on for 2 minutes 4 = follow alarm input 5 = on while telephone line 2 is looped
*51	Alternate LEDS	0,1	0	0= normal 1 = alternate LED functions
*52	Error Number	0,1	0	0 = no error number 1 = error numbers NOT IMPLEMENTED
*53	Emergency Dial Delay	0-60	00	Seconds for emergency dial to occur NOT IMPLEMENTED
*54	Alarm Message to Air Repeat Timer	000-255	060	Seconds between alarm message to air

*55	PRVA allowed	0,1	0	0 = no PRVA 1 = PRVA NOT IMPLEMENTED
*56	DTMF Rx min on detect	0-255	040	How long a DTMF digit has to be on for it to be detected as a valid tone (ms)
*57	DTMF Rx max off detect	0-255	040	How long a DTMF digit has to be off for it to be regarded as finished (ms)
*58	COM baud rate	0-5	3	0 = 1200 1 = 2400 2 = 4800 3 = 9600 4 = 19200 5 = 38400
*59	COM1 baud rate	0-5	3	Ditto
*60	COM2 baud rate	0-5	3	Ditto
*61	Gain line 1 to line 2	000-030		dB Gain from line 1 to line 2. NOT USED.
*62	Gain line 2 to line 1	000-030		dB gain from line 2 to line 1. NOT USED
*63	PIN to make telephone call	0,1	0	0 = no PIN 1 = PIN required to make call.
*64	PIN required to receive telephone call in manual answer mode	0,1	0	0 = * to answer call 1 = PIN to answer call
*65	ID required after PIN entry	0,1	0	0 = PIN can immediately be followed by number or command 1 = user must wait after PIN for TACT ID
*66	Confirm manual number	0,1	0	0 = Dial after number entry 1 = Announce before dial NOT IMPLEMENTED
*67	Line VOX Hang time (VOX persistence)	0-1000	0100	PTT hold after line VOX de-activates and audio delay is empty
*68	COS detect filter	0-1000	0100	ms how long a drop out is allowed in the COS signal.
*69	Line VOX detect window (VOX sensitivity) – see *13 also	00-15	12	20ms × xx size of line VOX window. Increasing the window size increases sensitivity.
*70	Line VOX count (VOX attack time)	00-15	05	How many signal samples in line VOX Detect Window for VOX activation. Number must be less than VOX Detect Window. Decreasing the count quickens attack time.
*71	Analogue radio transmit gain (Line → Radio Analog Tx Gain)	0-42	15	dB analogue Tx gain from phone to mobile radio 21 = 0dB
*72	Analogue radio receive gain (Radio → Line Analog Rx Gain)	0-42	18	dB analogue Rx gain from mobile radio to phone 21 = 0dB
*73	Digital gain radio to line (Radio → Line Digital Rx Gain)	0-99	46	dB digital Rx gain from radio 50 is 0dB
*74	Digital gain line to radio (Line → Radio Digital Tx Gain)	0-99	50	dB digital Tx gain to radio 50 is 0dB
*75	COS Sense	0,1	0	0 = COS active low 1 = COS active high
*76	Noise upper limit	0-255	100	qdB steps, sets upper limit for noise filters.
*77	COS Threshold	000 1-255	000 128	000 = digital (binary) input OR, Voltage reference relative to 5V. (128 = centre of COS swing 0 → 5V)
*78	No Rx (COS) from radio disconnect timer	1-255	060	s. How soon radio must transmit to line for connection to line to remain established.
*79	Radio VOX detect window (Radio VOX Sensitivity)	0-15	12	20ms × xx size of radio VOX window. Increasing the window size increases sensitivity.

*80	Radio VOX count (Radio VOX Attack Time)	0-15	03	How many signal samples in radio VOX Detect Window for VOX detection. Must be less than VOX Detect Window. Decreasing the count quickens attack time.
*81	Radio Absolute signal level detect (Radio VOX minimum activate level)	0-255	050	qdB. Minimum detect threshold for Radio. Bigger is less sensitive
*82	RS232 Modem COM Port Functionality	0,1	0	0 = RS232 COM port operation for modem 1 = Alarm Input operation with AI-4775
*83	Permanent Line Connection b/w two TACT units	0,1,2	0	0 = No permanent line connection 1 = MASTER permanent connection 2 = SLAVE permanent connection
*84	User Mode	0,1	0	0 = TA-4800 method of dialing phone numbers 1 = TA-7 method of dialing phone numbers
*85	VOX Override	0,1	0	0 = normal VOX operation 1 = DTMF 1 from phone forces PTT (Tx) and DTMF 2 from phone releases PTT (Tx).
*86	MAP 27 PTT Type	0,1	0	0 = Standard Mic PTT 1 = SRM9000 Option PTT
*#	Save and exit	-	-	Save changes and exit

Please note the following:

If you make changes to the above parameters, you will need to restart TACT by removing and then reapplying power before the changes will take effect.

Abbreviations:

ms = milliseconds dB = decibels
s = seconds qdB = quarter decibels
M = minutes

EPROM VERSION NUMBER

The firmware version reveals the vintage and features available with your TACT.

1. Press *48# on the TACT keypad to read back the EPROM version number.

CONNECTION DIAGRAM

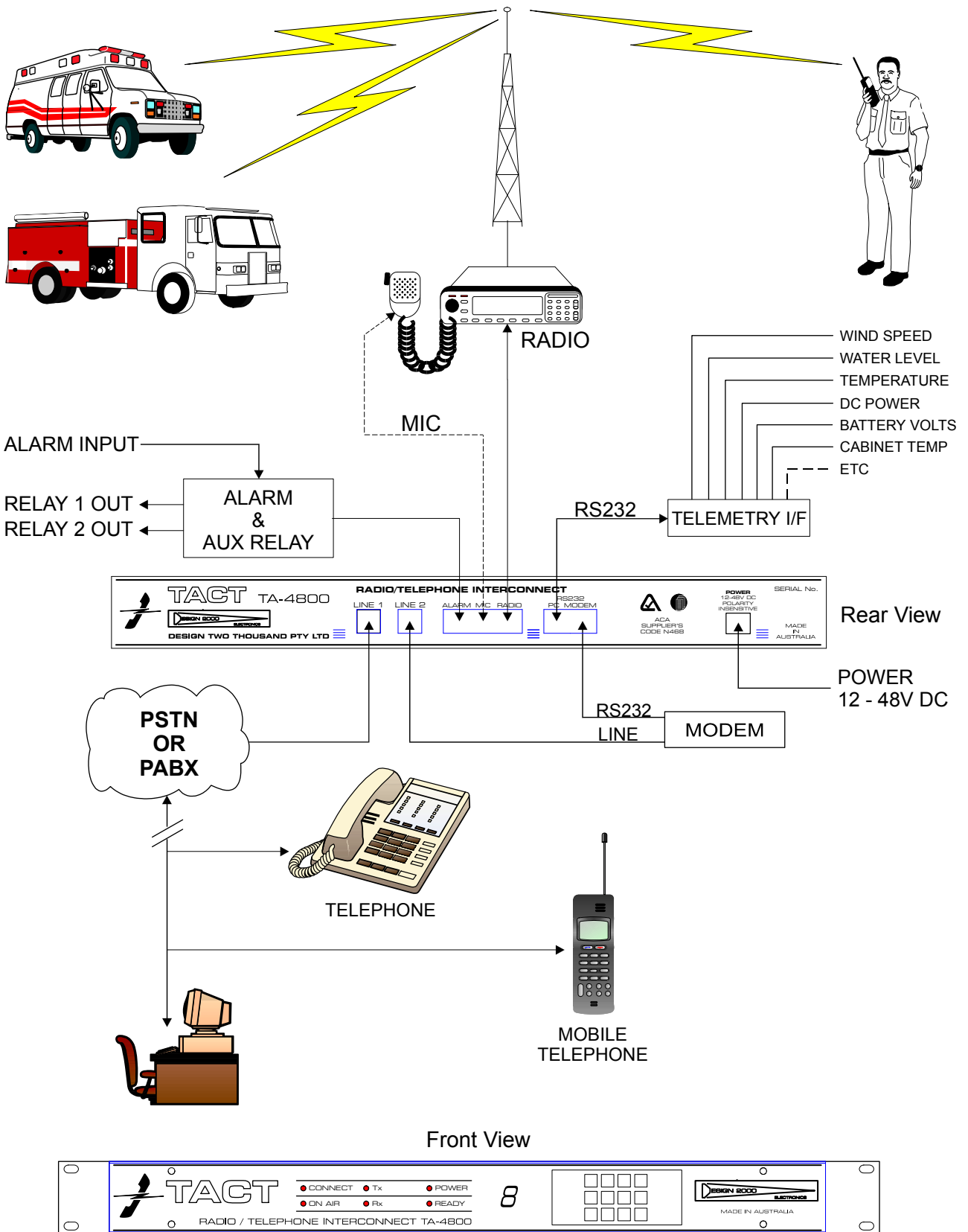

CONNECTIONS

RADIO (RJ45)

The radio interface connection

PIN	DESCRIPTION
1	PTT Common
2	PTT Normally Open
3	MAP 27 (Digital) Out
4	COS Indication from Radio
5	MAP 27 (Digital) In
6	Signal Ground (Return) (OV)
7	Audio Out from TACT to Radio (Tx)
8	Audio In to TACT from Radio (Rx)

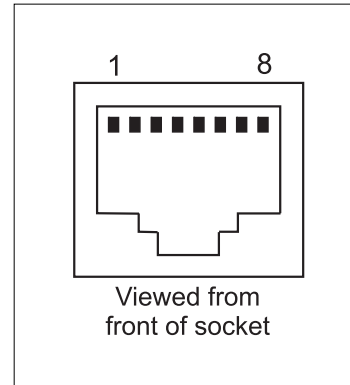

TELEPHONE

LINE 1 (RJ12)

PSTN line, PABX extension or VoIP FXS or ATA port connection

PIN	DESCRIPTION
1	
2	
3	Ring (Lb)
4	Tip (La)
5	
6	

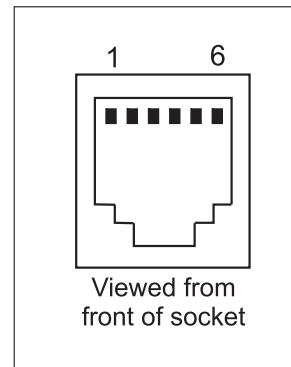

LINE 2 (RJ12)

An optional second Line connection
(sometimes an internal PABX extension)

PIN	DESCRIPTION
1	
2	
3	Ring (Lb)
4	Tip (La)
5	
6	

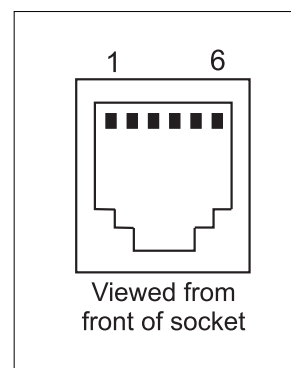

ALARM INPUT & AUXILIARY OUTPUT RELAYS (RJ45)

For the connection of an external alarm system. A contact closure fires off the TACT alarm dialler and the Alarm message to air. Two Auxiliary output relays are also provided to trigger external devices. The output relays are controlled from the telephone or radio using DTMF.

PIN	DESCRIPTION
1	Relay 1 Normally Open
2	Relay 1 Common
3	Relay 1 Normally Closed
4	Alarm In
5	Ground
6	Relay 2 Normally Open
7	Relay 2 Common
8	Relay 2 Normally Closed

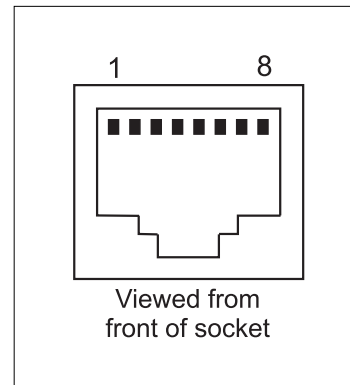

PC RS232 (Configured as DCE) (RJ45)

RS232 Serial COM port for a PC. Used at the factory for diagnostic purposes and reserved for future custom applications such as call logging.

PIN	DESCRIPTION
1	CD (Common to Modem)
2	RI (Common to Modem)
3	RXD (Data received by PC)
4	DTR (Common to Modem)
5	TXD (Data Transmitted by PC)
6	Ground
7	RTS (Common to Modem)
8	CTS (Common to Modem)

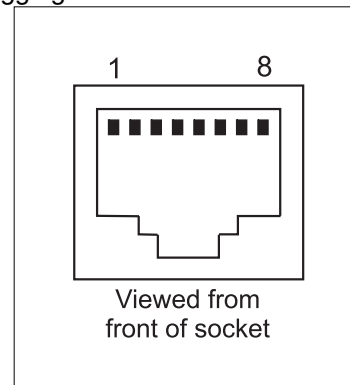

MODEM RS232 (Configured as DCE) & ALARM INPUT EXPANDER (RJ45)

RS232 Serial COM port for a modem. Reserved for future custom applications possibly involving a modem controlled by the PC.

PIN	DESCRIPTION
1	CD (Common to PC)
2	RI (Common to PC)
3	RXD (Data received by Modem) OR AI-4775 RXD Alarm Input Expansion Module
4	DTR (Common to PC)
5	TXD (Data Transmitted by Modem) OR AI-4775 TXD Alarm Input Expansion Module
6	Ground OR AI-4775 GND Alarm Input Expansion Module
7	RTS (Common to PC)
8	CTS (Common to PC)

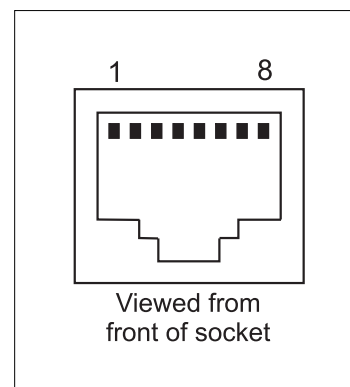

MIC

This is an auxiliary audio I/O accessory connector. It's most common use is to monitor both-way audio via a set of self-powered PC type speakers.

PIN	DESCRIPTION
1	Relay Common contact
2	Relay Normally Open contact
3	
4	
5	
6	Ground
7	Audio out for recording
8	Audio in from a microphone

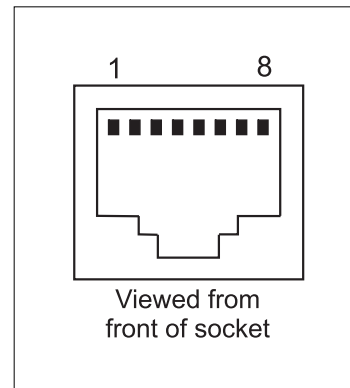

POWER (BL2)

For power input connection, usually 13.8 Vdc nominal.

PIN	DESCRIPTION
1	+12 Vdc nom.
2	-ve Return

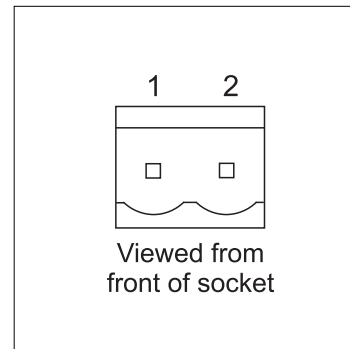

INTERNAL JUMPER (LINK) SETTINGS

LINK	FUNCTION	MADE	OPEN
LK15	Input Impedance	600 Ohms input impedance for Rx audio from Radio.	4k7 Ohms (high) input impedance for Rx audio from Radio.
LK16	Talk Through	Repeater audio (Rx from radio to Tx of radio) looped back. LK16 provides an audio path from the Rx audio to the Tx audio of the repeater. This provides an audio path on the repeater for normal radio traffic when TACT is idle or down-powered.	Rx from radio to Tx of Radio not looped back.

AUDIO LEVEL ADJUSTMENTS

Please Note: The TA-4800 Tx and Rx audio levels are factory preset to suit most popular radios. Therefore field adjustment is generally not required, and we recommend that you try using TACT before attempting the following set up procedures. It is also recommended that you use parameters *71 and *72 in the System Configuration menu if tweaking of the Tx and Rx levels is required.

AUDIO OUTPUT TO RADIO (Tx LEVEL) (SETTING THE MODULATION LEVEL)

This procedure is to adjust the Tx audio level from the telephone line to the radio.

The audio output from TACT to the radio is found on Pin 7 of the 'RADIO' connector. It can be connected to the radio's mic input or similar point. The TACT keypad is used to adjust the audio level to radio for correct modulation. If using microphone sensitivity input, a 10:1 resistive voltage divider across the mic input circuit is recommended.

The Tx level setting procedure is as follows:

1. Press *97# on the TACT keypad. TACT will respond by transmitting an 820 Hz test tone via the base radio to the mobile for 120 seconds. With an appropriate test set connected to the base radio transmitter output, repeatedly press * to increase or # to decrease the test tone (you can also press a digit 1 → 9 to select an absolute level and then fine tune with the * and # keys) until the test set indicates the correct modulation level. (Refer to the radio manufacturer's documentation and appropriate regulations for relevant specifications. For FM sets the signal should deviate the RF carrier 2.5kHz on systems with 25kHz channel spacing or 1.25kHz on systems with 12.5kHz channel spacing).
 - If a suitable test set is not available, use an ac Volt meter to monitor the input to the radio and repeatedly press * to increase or # to decrease the signal level to match the input specifications of the radio. For example, a radio may require 100 mV at its input. (You can also adjust the level by ear. Listen to the test tone on a receiving mobile, and using the procedure described above, adjust the level until it sounds clear and free of distortion).
2. Press 0 to save and exit. TACT reads back a two digit value for Option *71 in the system configuration options.

AUDIO INPUT FROM RADIO (Rx LEVEL)

This procedure is to adjust the Rx audio level from the radio to the telephone line.

Audio output from the radio (300 → 500 mV p-p recommended) is fed into TACT via Pin 8 of the 'RADIO' connector. As a last resort, the radio speaker output may be used as the audio source. The input impedance of the TACT radio receive audio port is normally 10K Ohms or 600 Ohms nominal with LK15 linked.

To meet ACA specifications, the DTMF audio level from TACT to line should not exceed -6dBm. The radio being used should be adjusted so that -6dBm to line is not exceeded.

The easiest method to calibrate the Rx level to line without expensive or additional equipment is as follows:

1. Make sure that the level from radio to TACT is less than 1V RMS.
2. Connect the telephone line to Line 1 OR apply a dc loop current (from part number LI-4302 active line driver) to line 1. Place a dB or ac Volt meter across the line.
3. Press *98# on the TACT keypad.
4. Press and hold 5 on a mobile radio keypad to provide a continuous tone from the radio to the TACT.
5. Repeatedly press (on the TACT keypad) * to increase or # to decrease the signal (you can also press a digit 1 → 9 to select an absolute level and then fine tune with the * and # keys) so that the output level is around -6dBm or 0.388 V RMS.
 - **You can also observe the TACT display and adjust the level until the display just changes from 6 to 7.**
6. Press 0 to save and exit. TACT reads back a two digit value for Option *72 in the system configuration options.

PTT AND COS

PRESS TO TALK (PTT) OUTPUT TO RADIO

Description

A relay is provided to apply press to talk (PTT) to the radio when the transmitter is to be keyed. Keying the transmitter also allows TACT to transmit audio from the telephone to the radio field. Normally a radio will require a contact closure to ground to activate its PTT (or key its transmitter).

Connection

'PTT Common' is on Pin 1 of the 'RADIO' connector and 'PTT Normally Open' is on Pin 2 of the 'RADIO' connector. The radio's Ground or 0V should be connected to Pin 1 and the radio's PTT input should be connected to Pin 2. If the radio requires a voltage input to activate its PTT then a suitable external voltage should be connected in series with Pin 2.

CARRIER OPERATED SQUELCH (COS) INPUT FROM RADIO

Description and Programming

TACT requires a COS signal from the base radio or repeater when it is receiving a transmission from a mobile. It may take the form of contact closure or a voltage.

TACT must be programmed accordingly:

*6703#		Range	Default	
*75	COS Sense	0,1	0	0 = COS active low 1 = COS active high
*77	COS Threshold	000	000	000 = digital (binary) input OR:
		1-255	128	Voltage reference relative to 5V. (128 = centre of COS swing 0 → 5V)
*#				

Normally, TACT is supplied configured for a contact closure and supplies +5V via 100K to the radio. 'COS Threshold' must then be set to 0 to denote a binary input, and the 'COS Sense' set to 0 if a contact closure to ground denotes a valid COS condition. 'COS Sense' is set to 1 if a valid COS is denoted by an open condition.

Should the radio present a voltage to indicate the COS condition, the 'COS Threshold' must be set to a number in the range 1 to 255 inclusive. 1 represents near 0V and 255 represents +5V. For example, if the radio presents a voltage in the range +0.5V to +3.0V, then the 'COS Threshold' would be set to $\{[(3.0V - 0.5V)/2 + 0.5V]/5V\} \times 255 = 89$, ie. in the middle of the input voltage range. Note that if either limit is outside the range 0 → 5V, for example -5V to +10V, then while the input is protected against modest voltage excess, only the portion from 0 → 5V is recognised and in such an instance the 'COS Threshold' would be set to 128, ie. half the sensing range. 'COS Sense' must then be set to 1 if the upper voltage represents valid COS or set to 0 if the lower voltage represents valid COS. Additionally, the voltage source in the radio must be capable of sinking the small current presented by the COS input, ie. about 50 micro Amps. If this is not so, then resistor R104 must be removed from TACT and re-installed into position R106.

Connection

The COS output from the radio is connected to Pin 4 of the 'RADIO' connector and is sensed relative to ground or 0V with Pin 6 of the 'RADIO' connector connected to the signal ground (0V) of the radio.

SUMMARY OF USER CODES

CODE	FACILITY	FROM
USER		
nnnnnnnn #	Make a telephone call	Radio
*	Restart dialing if you make a mistake during dialing	Radio
# #	End a telephone call	Radio or Phone
# #	Last number redial	Radio
*2 xx nnnnnnnn #	Store speed dial number in memory	TACT Keypad
# xx	Speed dial number from memory	Radio
*2 xx #	Check number in memory	TACT Keypad
# n # nnnnnnnn #	Select line and dial a number	Radio
# n # # xx	Select line and dial a speed dial number	Radio
*	Answer an incoming call	Radio
* 78 #	Record announcement	Phone
#	End recording	Phone
* 79 #	Review announcement	Phone
* 78 ##	Turn off and erase PRVA	Phone
* 79 ##	Enable Standard Caller announcement & erase previous recording	Phone
* 30 #	Called Indicator	Radio
* 31 #	Call counter	Radio
* 31 0 #	Reset call counter	Radio
*# p... #	Program system PIN	TACT Keypad
*# p... #	Change system PIN	TACT Keypad
p...	PIN access to TACT	Phone or Radio
* 1	Place call on hold	Radio
* 1	Take call off hold	Radio
## * 1	End call in progress and answer call on other line	Radio
* 1 *	Hold call in progress and answer call on other line	Radio
* 2	Alternate between calls on hold	Radio
* 3	Conference (<i>not yet implemented</i>)	Radio
## * 1	Hang up and return to the other call on hold	Radio
	<i>(Not yet implemented)</i>	
* 59 nn #	Call barring (number of digits allowed to be dialed)	TACT Keypad
* 59 #	Check number of digits allowed to be dialed	TACT Keypad

FACTORY OPTIONS

* 81 x nnnnnnnn #	Alarm dial number one	TACT Keypad
* 82 x nnnnnnnn #	Alarm dial number two	TACT Keypad
* 83 x nnnnnnnn #	Alarm dial number three	TACT Keypad
* 84 x nnnnnnnn #	Alarm dial number four	TACT Keypad
* 8n 0 #	Erase alarm dial number	TACT Keypad
#	Stop dialer from phone.	Phone
* 07 0 #	Reset auxiliary relay one	Radio or Phone
* 07 1 #	Operate auxiliary relay one	Radio or Phone
* 07 #	Interrogate relay one state	Radio or Phone
* 08 0 #	Reset auxiliary relay two	Radio or Phone
* 08 1 #	Operate auxiliary relay two	Radio or Phone
* 08 #	Interrogate relay two state	Radio or Phone
* 72 nn #	Two tone page (Quickcall)	Phone
* 75 nnnnn #	Five tone page (Selcall)	Phone
* 42 nnn # xx	Store two tone page in memory	TACT Keypad
* 45 nnnnn # xx	Store five tone page in memory	TACT Keypad
* 4 xx #	Speed dial quickcall or selcall from memory	TACT Keypad
* 6	Hook flash	Radio
* 90 #	Ring local telephone from mobile	Radio
* 91 1 #	Local telephone privacy mode on	Local Phone
* 91 0 #	Local telephone privacy mode off	Local Phone

SYSTEM

*67709600#	Reset system programming only, PMR	TACT Keypad
*67709601#	Reset system programming only, MPT1327/MAP27	TACT Keypad
*67709602#	Reset system programming only, Serial Control	TACT Keypad
*67709603#	Reset system programming only, MOTOTRBO DTP	TACT Keypad
*67709604#	Reset system programming only, Kenwood NXDN	TACT Keypad
*67709605#	Reset system programming only, Hytera DMR mobile	TACT Keypad
*67709606#	Reset system programming only, CODAN Serial Control	TACT Keypad
*67709630#	Reset numbers to default only	TACT Keypad
*67709609#	PIN reset	TACT Keypad

*67 PIN #, default PIN = 1234	Remote Access to Programming	TACT Keypad
* 67 03 #	System configuration access	TACT Keypad
* nn	Option number	TACT Keypad
n...	Entry	TACT Keypad
#	Scroll	TACT Keypad
* *	Abort	TACT Keypad
* #	Store & end	TACT Keypad
#*#	Exit Remote Programming	TACT Keypad

* 48 #	EPROM version number	TACT Keypad
--------	----------------------	-------------

SPECIFICATIONS

Enclosure		1U high, 19" rack mount, 250mm deep.
Finish		Dulux metallic charcoal powder coat.
Power Requirement		12V d.c. nominal, ground insensitive.
Power Consumption		300 mA @ 12V
Initial Start Up Current		750 mA for 90 ms @ 12V
Operating Temperature Range		-10 → 60 ° C.
Storage Temperature Range		-20 → 80 ° C ambient.
Humidity, Storage and Operating		To 98% non condensing.
Mean Time Between Failure		> 20 years.
TACT Radio Interface	IN	4K7 → 10K Ohm input impedance.
		Strappable 600 Ohm termination.
	OUT	600 Ohm output impedance.
Input level		-30 → +6 dBm adjustable (-13.5 dBm nom.).
Output level		-30 → +6 dBm adjustable. (-13.5 dBm nom.).
Frequency range		300 Hz → 5 kHz.
COS detect		High impedance input, floating to +5V, grounded by radio to indicate COS (inverted sense programmable).
PTT		Relay contact, switching to ground for PTT activation.
Telephone Line Interface		Standard two wire analogue ring in/loop out.
Ringer Equivalent Number (REN)		0.5.
Ring Detect		≥ 10V RMS @ 13-55 Hz (25 Hz nominal), ≥100 ms.
Answer Delay		100 ms minimum.
Impedance		Selectable TN12 Complex (220Ω + 120nF//820Ω) or TN6 (600 Ω). TN1 -4, TN7 - 8 also available.
In-band Signalling		<u>D</u> ual <u>T</u> one <u>M</u> ulti <u>F</u> requency (DTMF).
DTMF Dialler		100 ms on/off, -10dBm.
DTMF Receiver		-40 → 0 dBm sensitivity.
5 Tone Paging Protocol		CCIR 40 ms.
Keypad		12 push button 4 x 3 numeric silicone membrane keypad.
Displays		7 segment numeric readout, 6 x status LEDs.
RS232 Port		9600 baud, N81 format.
Telephone Service Tone detection		-30 dBm sensitivity, automatic cadence detection.
ACMA Supplier Code		N468
ERAC Responsible Supplier Number		E1287
New Zealand Telepermit		PTC 210/96/003
Warranty		Two years
Firmware Storage Medium		EPROM
System Number		V4833.62 or later
		V4833.55 (for MPT1327)
Speech Number		V99477.02
		V4901.03 (for MPT1327)
		No Speech (for TRBO™ DTP)

SPEED DIAL INDEX

MEMORY	NAME	NUMBER	MEMORY	NAME	NUMBER
# 00			# 50		
# 01			# 51		
# 02			# 52		
# 03			# 53		
# 04			# 54		
# 05			# 55		
# 06			# 56		
# 07			# 57		
# 08			# 58		
# 09			# 59		
# 10			# 60		
# 11			# 61		
# 12			# 62		
# 13			# 63		
# 14			# 64		
# 15			# 65		
# 16			# 66		
# 17			# 67		
# 18			# 68		
# 19			# 69		
# 20			# 70		
# 21			# 71		
# 22			# 72		
# 23			# 73		
# 24			# 74		
# 25			# 75		
# 26			# 76		
# 27			# 77		
# 28			# 78		
# 29			# 79		
# 30			# 80		
# 31			# 81		
# 32			# 82		
# 33			# 83		
# 34			# 84		
# 35			# 85		
# 36			# 86		
# 37			# 87		
# 38			# 88		
# 39			# 89		
# 40			# 90		
# 41			# 91		
# 42			# 92		
# 43			# 93		
# 44			# 94		
# 45			# 95		
# 46			# 96		
# 47			# 97		
# 48			# 98		
# 49			# 99		
			##	Last Number Redial	

TO STORE NUMBER: Press *2 xx nnnn nnnn #
 TO SPEED DIAL NUMBER: Press # xx
 TO DELETE STORED NUMBER: Press *2 xx 0 #

TACT MODEL TA-4800



Designed and Manufactured By:

design2000

DESIGN TWO THOUSAND PTY LTD

9-11 ROSE STREET
UPPER FERNTREE GULLY
MELBOURNE
VICTORIA 3156
AUSTRALIA

Telephone: (03) 9758 5933
E-mail: gen@design2000.com.au

Facsimile: (03) 9758 5560
Web Site: www.design2000.com.au

DESIGN TWO THOUSAND PTY LTD IS CERTIFIED TO ISO9001



ACMA Supplier Code: N468
ERAC Responsible Supplier Number: E1287

